

1. Description

These N-Channel enhancement mode power field effect transistors are produced using Fairchild's proprietary, planar stripe, DMOS technology. This advanced technology has been especially tailored to minimize on-state resistance, provide superior switching performance, and withstand high energy pulse in the avalanche and commutation mode. These devices are well suited for high efficient switched mode power supplies, active power factor correction, electronic lamp ballast based on half bridge to pology.

2. Features

- n 9A, 900V, $R_{DS(on)}=1.12\Omega$ @ $V_{GS}=10$ V
- n Low gate charge (typical 70 nC)
- n Low Crss (typical 14pF)
- n Fast switching
- n 100% avalanche tested
- n Improved dv/dt capability
- n RoHS compliant

3. Pin configuration

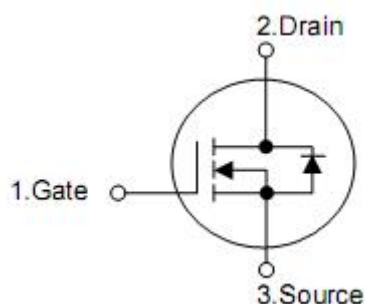

Pin	Function
1	Gate
2	Drain
3	Source

4. Absolute maximum ratings

(T_C= 25 °C , unless otherwise specified)

Parameter	Symbol	Ratings	Units
Drain-source voltage	V _{DSS}	900	V
Drain current	I _D	T _C =25°C	9.0
		T _C =100°C	5.7
Drain current (note1)	I _{DM}	36	A
Gate-source Voltage	V _{GSS}	± 30	V
Single pulsed avalanche energy (note2)	E _{AS}	900	mJ
Avalanche current (note1)	I _{AR}	9.0	A
Repetitive avalanche energy (note1)	E _{AR}	28	mJ
Peak diode recovery dv/dt (note 3)	dv/dt	4.0	V/ns
Power dissipation	P _D	T _C =25°C	280
		Derate above 25°C	2.22
Operating and storage temperature range	T _J , T _{STG}	-55 to +150	°C
Maximum lead temperature for soldering purposes, 1/8" from case for 5 seconds	T _L	300	°C

5. Thermal characteristics

Parameter	Symbol	Typ	Max	Units
Thermal resistance, junction-to-case	R _{θJC}	-	0.45	°C/W
Thermal resistance, case-to-sink	R _{θCS}	0.24	-	°C/W
Thermal resistance, junction-to-ambient	R _{θJA}	-	40	°C/W

6. Electrical characteristics

(T_C=25°C, unless otherwise notes)

Parameter	Symbol	Test Conditions	Min	Typ	Max	Units
Off characteristics						
Drain-source breakdown voltage	BV _{DSS}	V _{GS} =0V, I _D =250μA	900	-	-	V
Zero gate voltage drain current	I _{DSS}	V _{DS} =900V, V _{GS} =0V	-	-	10	μA
		V _{DS} =720V, T _C =125°C	-	-	100	μA
Gate-body leakage current	Forward	I _{GSS}	-	-	100	nA
	Reverse				-100	nA
Breakdown voltage temperature coefficient	ΔBV _{DSS} /ΔT _J	I _D =250μA Referenced to 25°C	-	0.9	-	V/°C
On characteristics						
Gate threshold voltage	V _{GS(th)}	V _{DS} =V _{GS} , I _D =250μA	3.0	-	5.0	V
Static drain-source on-resistance	R _{DS(on)}	V _{GS} =10V, I _D =4.5A	-	1.12	1.4	Ω
Forward transconductance	g _{FS}	V _{DS} =40V, I _D =4.5A (note4)	-	9.0	-	S
Dynamic characteristics						
Input capacitance	C _{ISS}	V _{DS} =25V, V _{GS} =0V, f=1MHz	-	2780		pF
Output capacitance	C _{OSS}		-	228		pF
Reverse transfer capacitance	C _{RSS}		-	28		pF
Switching characteristics						
Turn-on delay time	t _{D(ON)}	V _{DD} =450V, I _D =9.0A, R _G =25Ω (note4, 5)	-	55		ns
Rise time	t _R		-	130		ns
Turn-off delay time	t _{D(OFF)}		-	110		ns
Fall time	t _F		-	80		ns
Total gate charge	Q _G	V _{DS} =720V, I _D =9.0A, V _{GS} =10V (note4, 5)	-	70		nC
Gate-source charge	Q _{GS}		-	13.5	-	nC
Gate-drain charge	Q _{GD}		-	27	-	nC
Drain-source diode characteristics and maximum ratings						
Maximum continuous drain-source diode forward current	I _S		-	-	9.0	A
Maximum pulsed drain-source diode forward current	I _{SM}		-	-	36.0	A
Drain-source diode forward voltage	V _{SD}	V _{GS} =0V, I _S =9.0A	-	-	1.4	V
Reverse recovery time	t _{RR}	V _{GS} =0V, I _S =9.0A, di _F /dt=100A/μs (note 4)	-	850	-	ns
Reverse recovery charge	Q _{RR}		-	10	-	μC

- Note: 1. Repetitive rating : pulse width limited by maximum junction temperature
2. L=21mH, I_{AS}= 9.0A, V_{DD}=50V, R_G=25Ω, starting T_J=25°C
3. I_{SD}≤9.0A, di/dt≤200A/μs, V_{DD}≤BV_{DSS}, Starting T_J=25°C
4. Pulse test : pulse width≤300μs, duty cycle≤2%
5. Essentially independent of operating temperature

7. Test circuits and waveforms

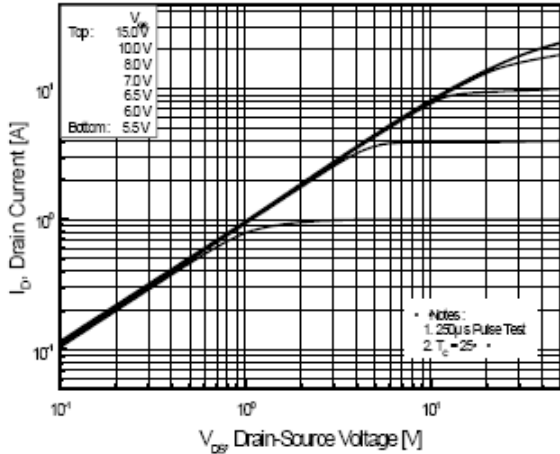

Figure 1. On-Region Characteristics

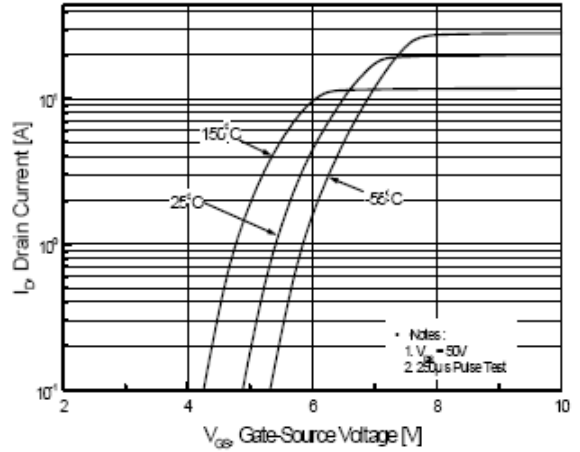

Figure 2. Transfer Characteristics

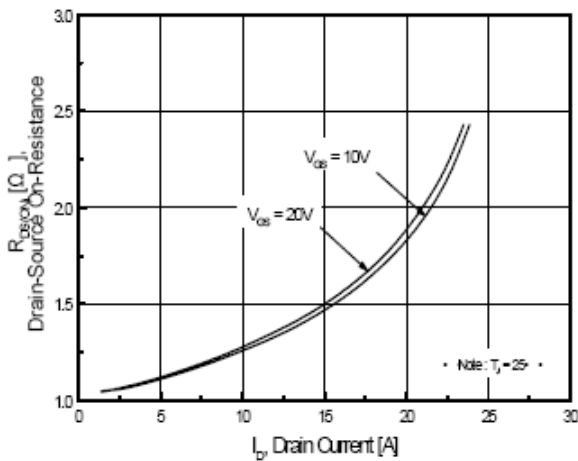

Figure 3. On-Resistance Variation vs. Drain Current and Gate Voltage

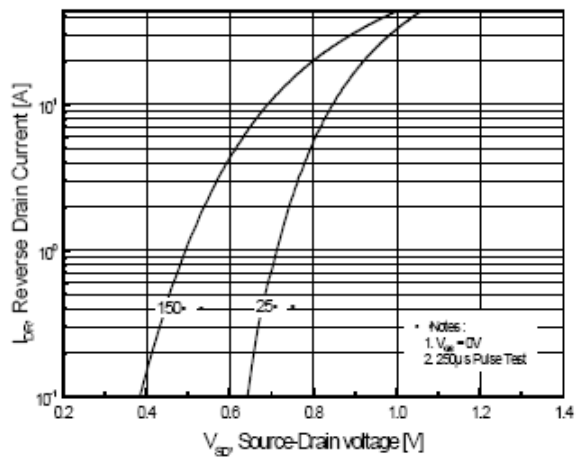

Figure 4. Body Diode Forward Voltage Variation vs. Source Current and Temperature

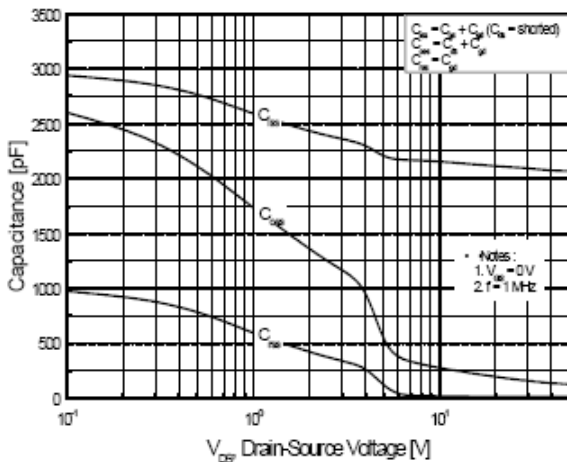

Figure 5. Capacitance Characteristics

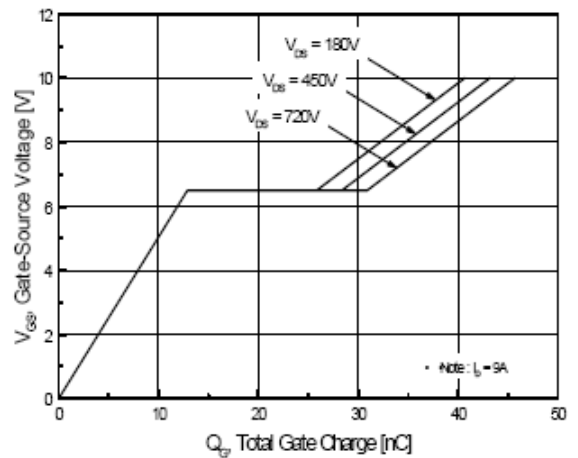

Figure 6. Gate Charge Characteristics

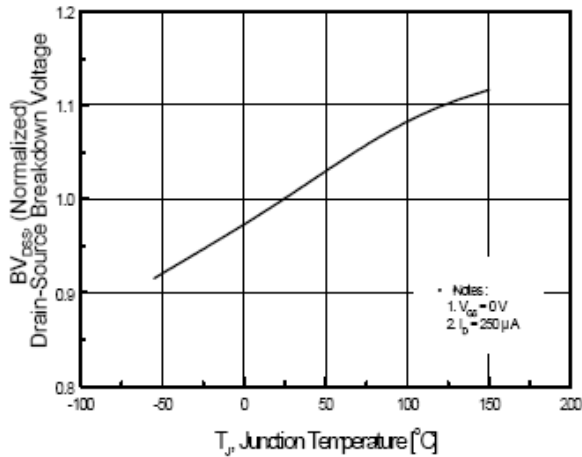

Figure 7. Breakdown Voltage Variation vs. Temperature

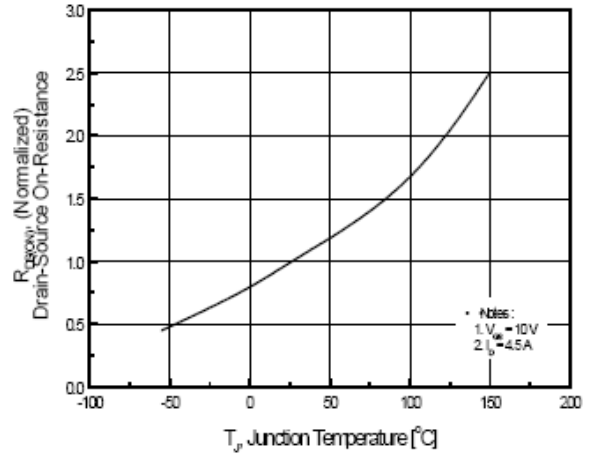

Figure 8. On-Resistance Variation vs. Temperature

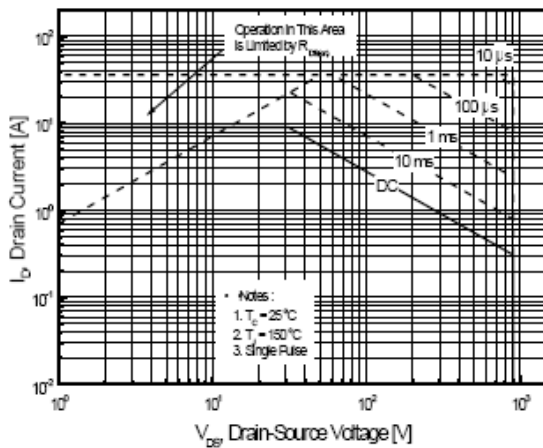

Figure 9. Maximum Safe Operating Area

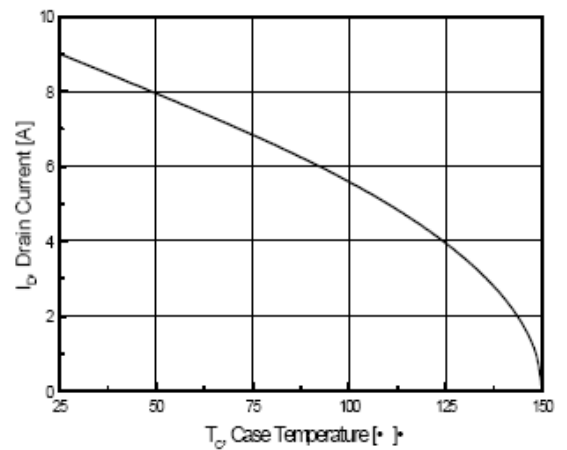

Figure 10. Maximum Drain Current vs. Case Temperature

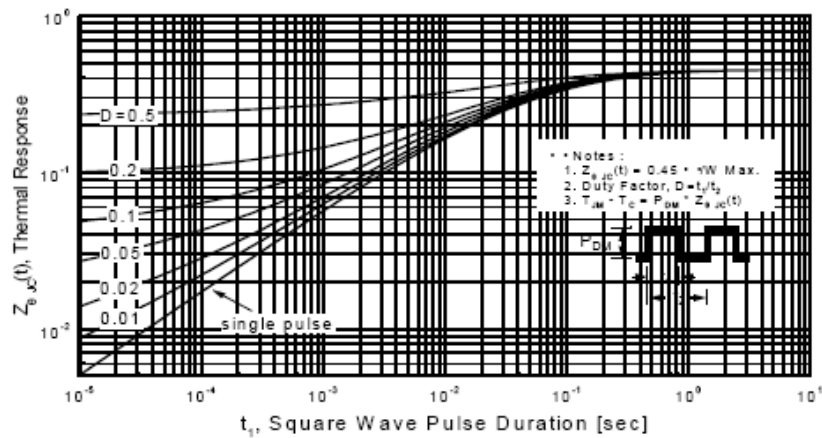
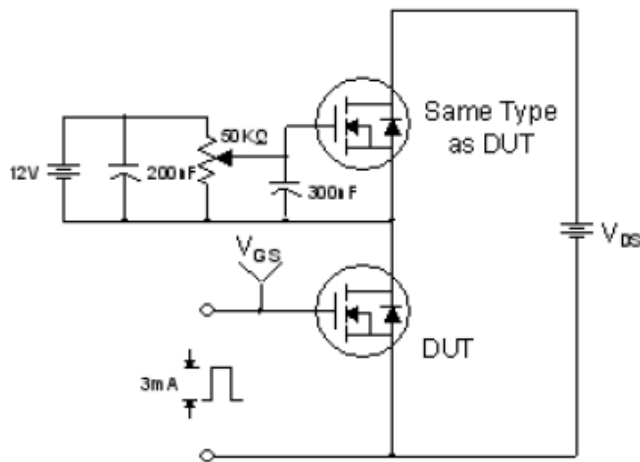
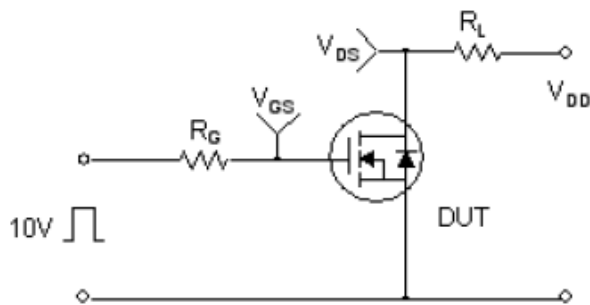

Figure 11. Transient Thermal Response Curve



Gate Charge Test Circuit & Waveform



Resistive Switching Test Circuit & Waveforms

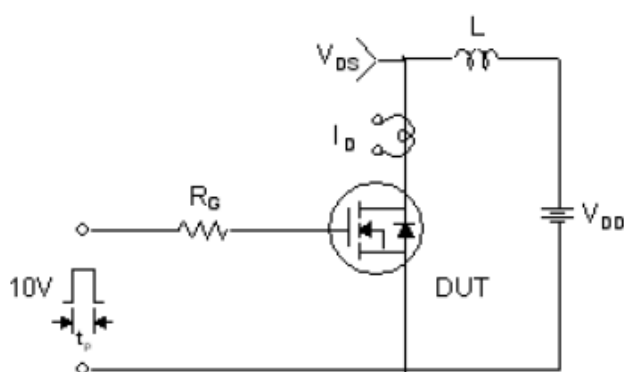

Unclamped Inductive Switching Test Circuit & Waveforms

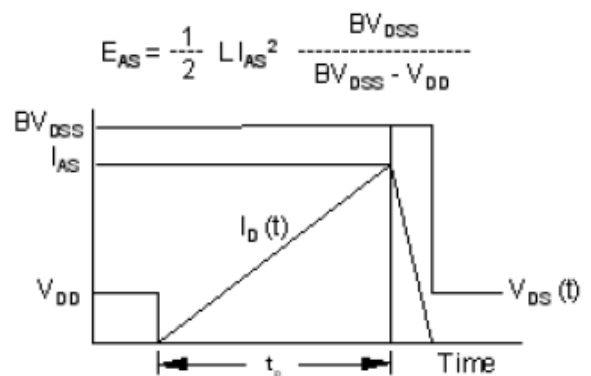
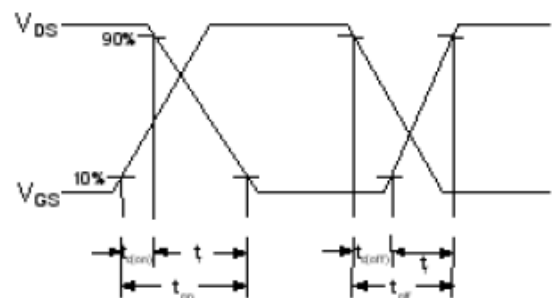
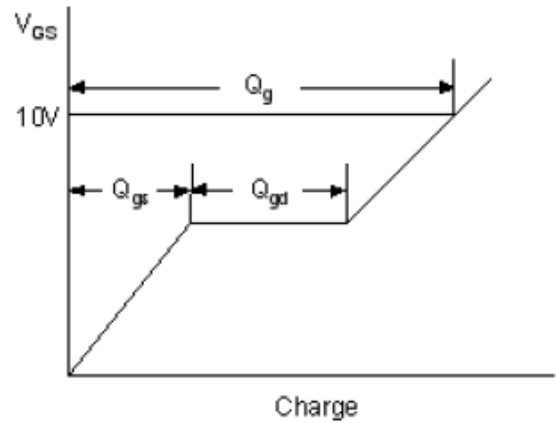

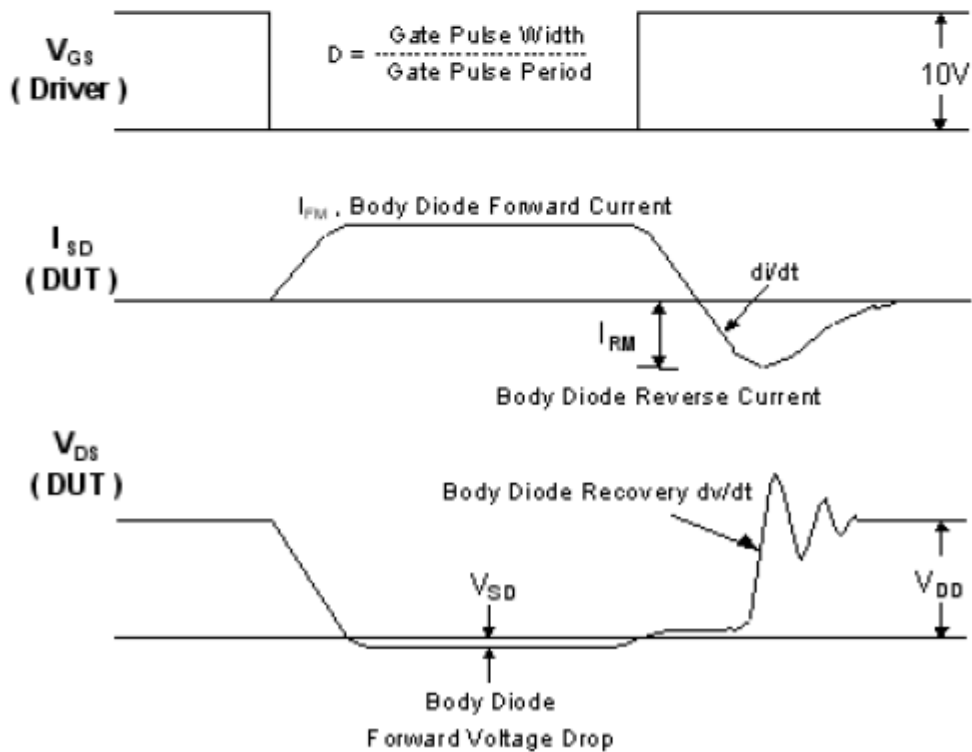
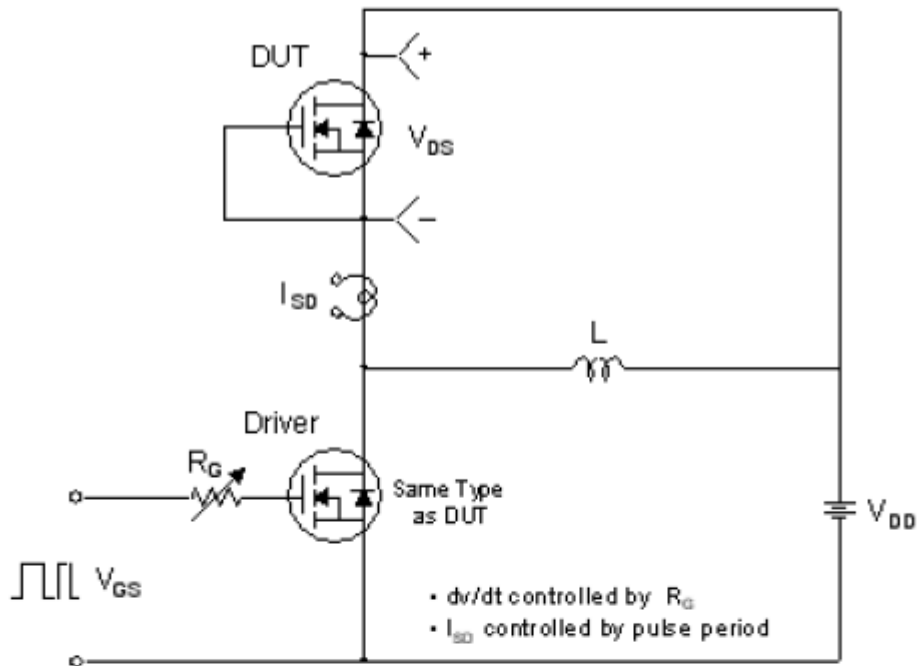

Peak Diode Recovery dv/dt Test Circuit & Waveforms